

RICONNESSIONI!

educazione al futuro

When passion is unlocked

Learning can take place

Teaching is more effective

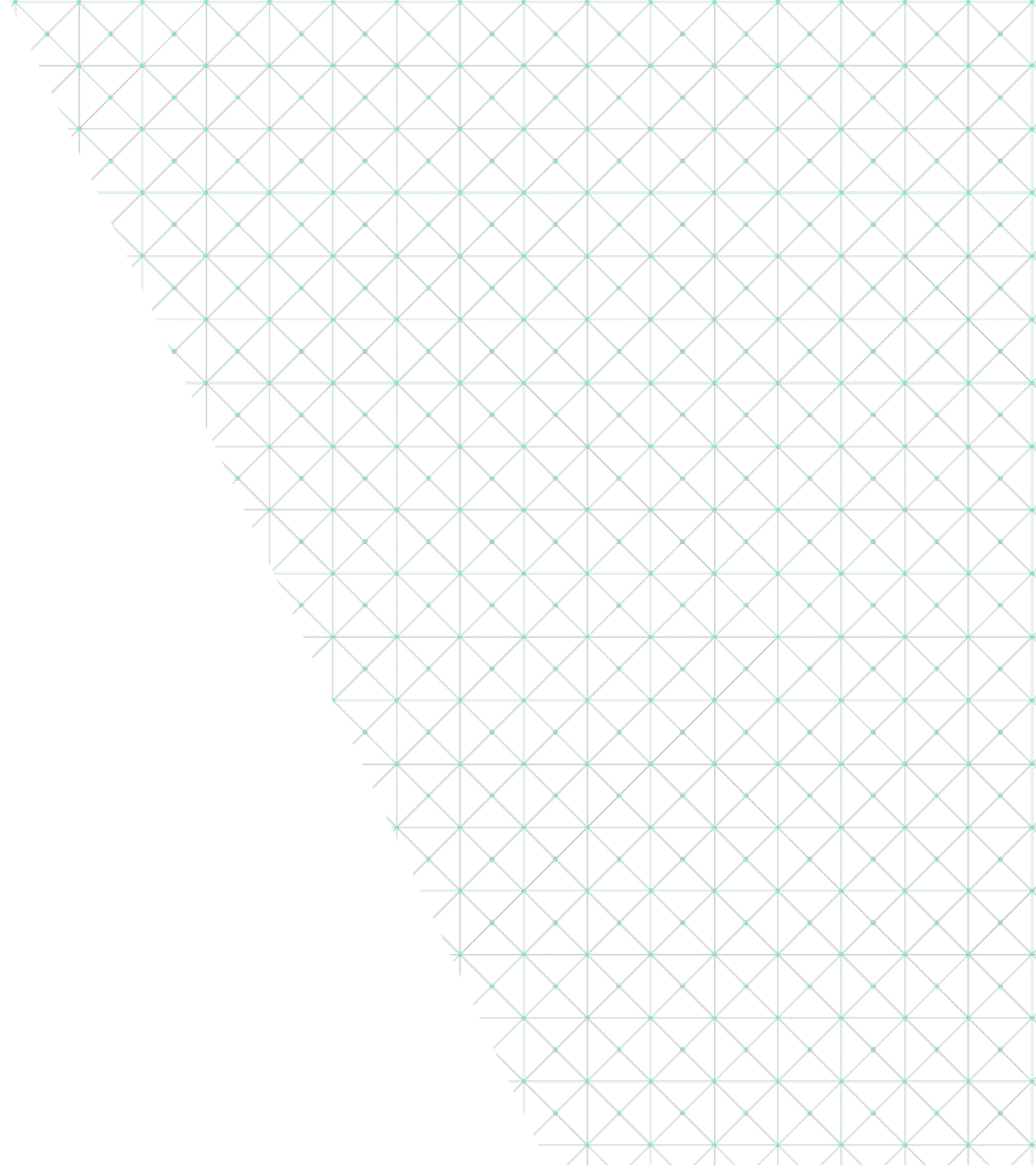

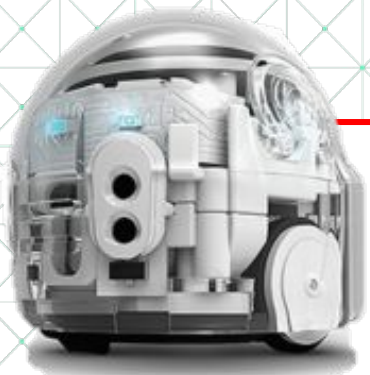

Ozobot

Labirinto

Ozobot

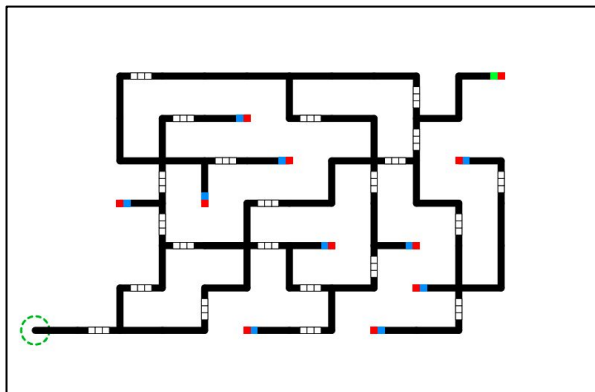

compleso

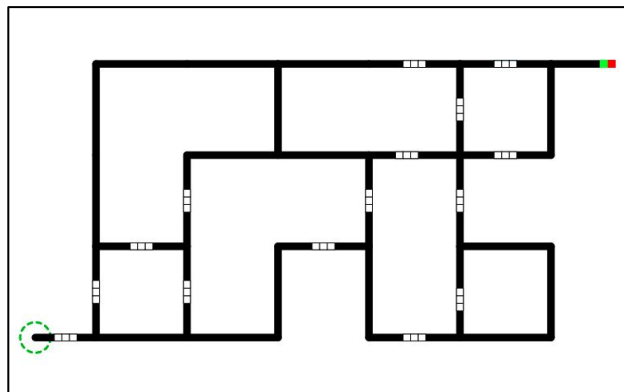

medio

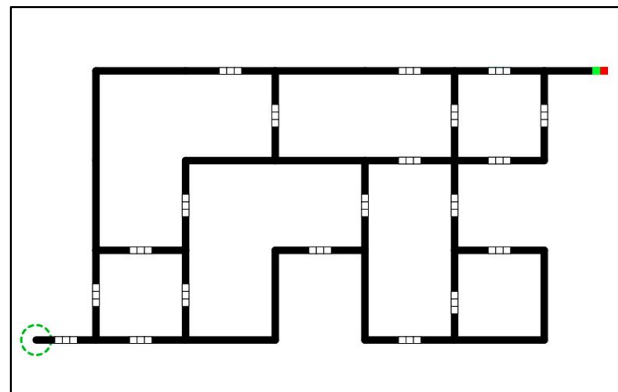

semplice

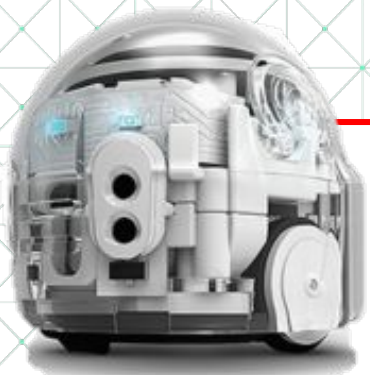

Ozobot

 Gara

 Ozobot

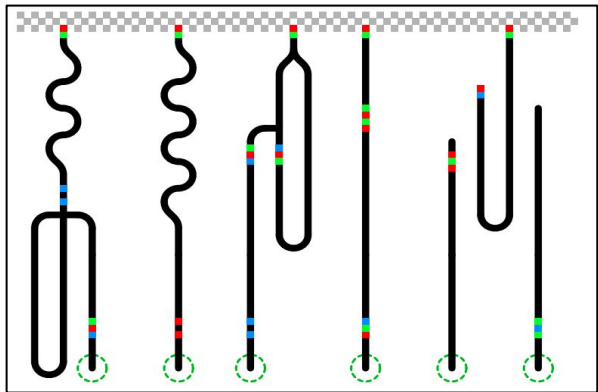

 Ozobot multipli

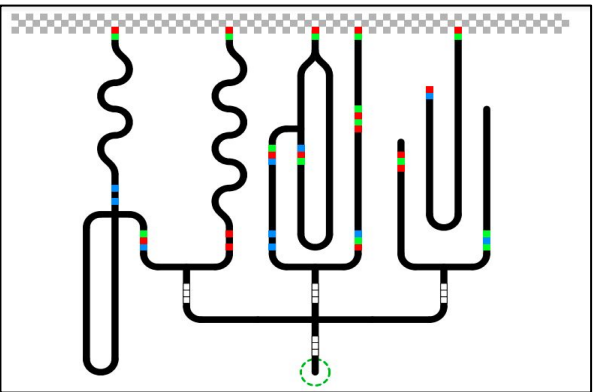

 Ozobot singolo

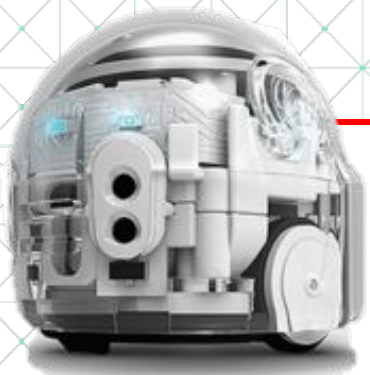

Ozobot

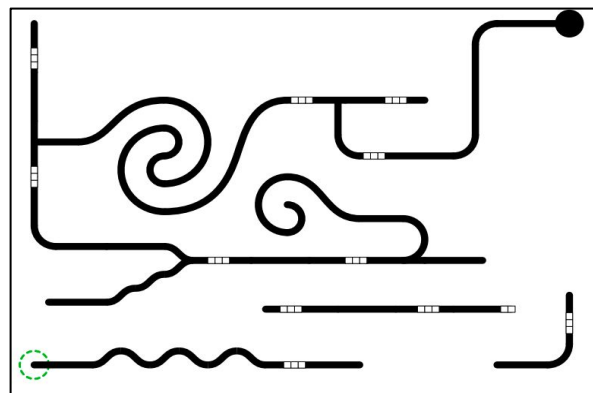

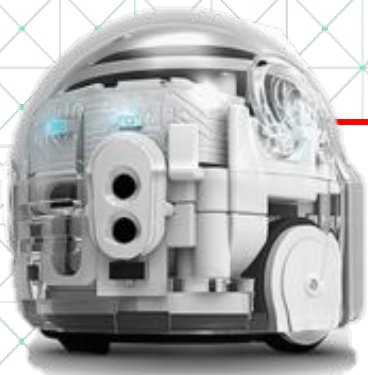

Ozobot

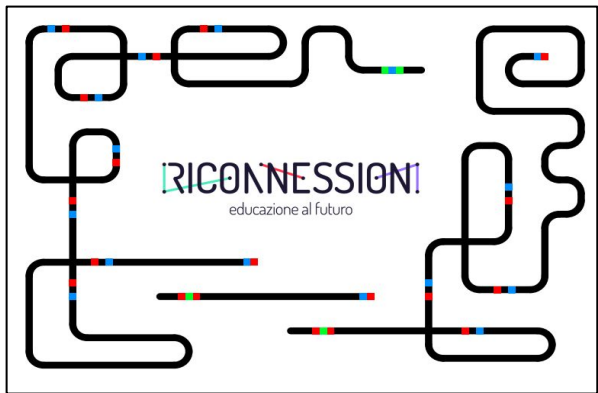

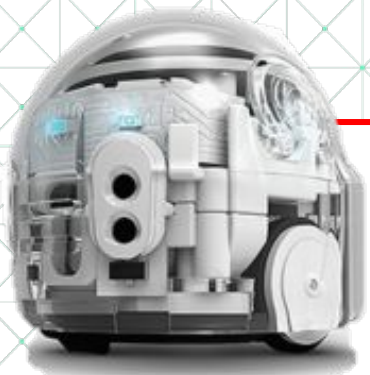

Ozobot

 Circuitino

 Ozobot

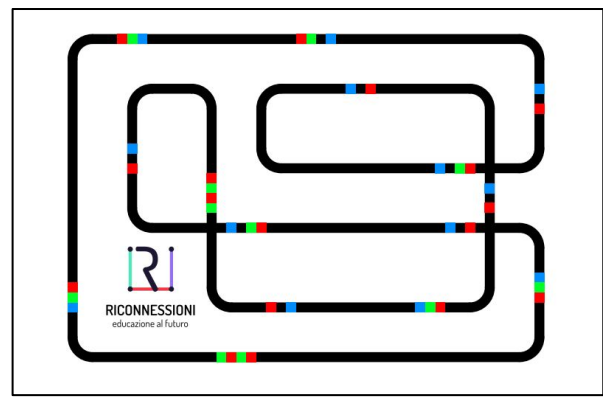

 Circuitino A4



Ozobot

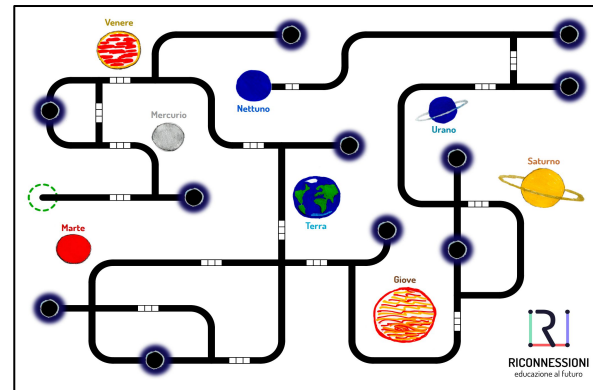

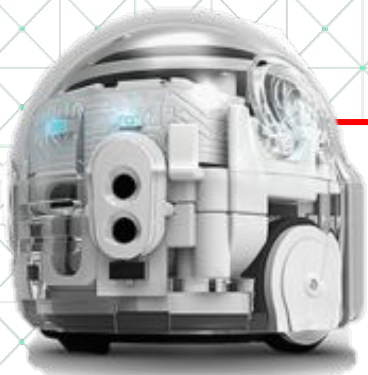

Ozobot



Ozobot in città



Ozobot

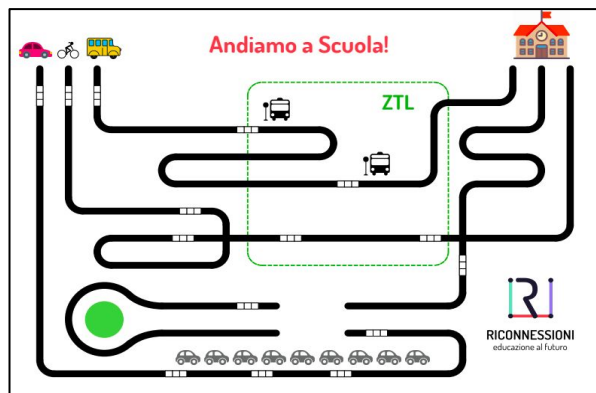

Andiamo a scuola!

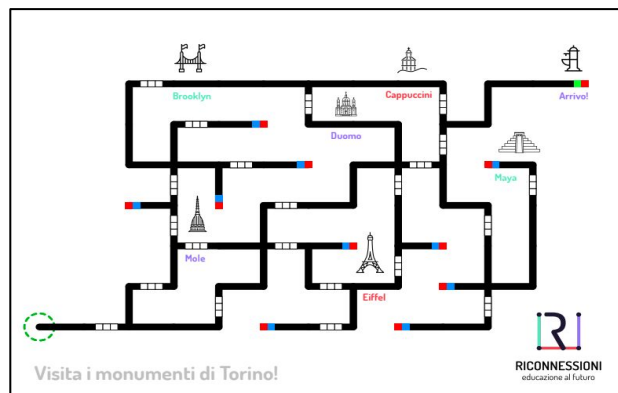

Monumenti

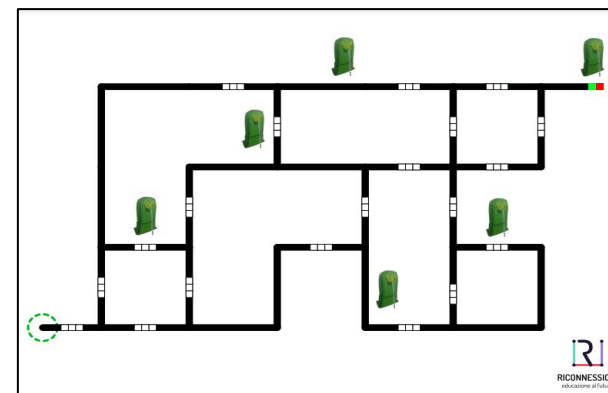

Turet semplice

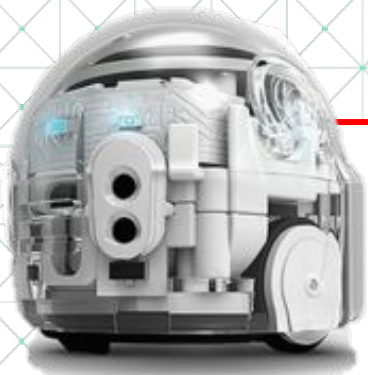

Ozobot

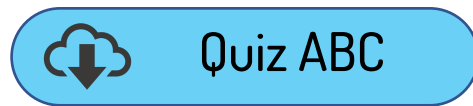
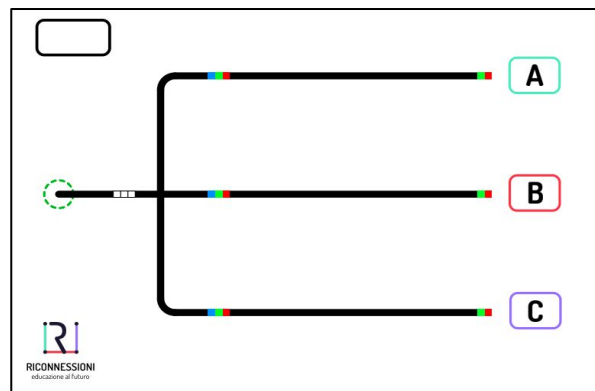

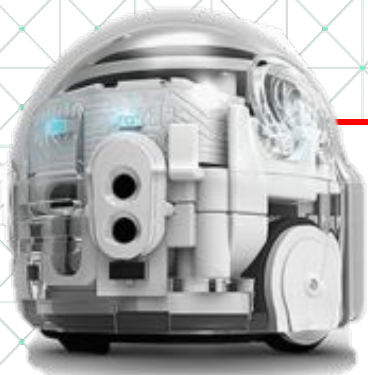

Ozobot



Codici colore



| Color Codes Chart | | | | | |
|---|--|--------------------------------------|---------------------------------|-------------------------------|----------------------------|
| Speed | | | | | |
| Short Super Slow R G B | Slow R BK G | Cruise G BK G | Fast B BK B | Turbo B G B | Nitro Boost B G R |
| Direction & Special Moves | | | | | |
| Left at Intersection G BK R | Straight at Intersection B BK R | Right at Intersection B R G | Line Switch Left G R G | Line Switch Straight G B G | Line Switch Right R G R |
| U Turn B R B | U Turn (line end) B R | Turnabout R G R G | Zigzag B BK G R | Split G R G R | Backward R G BK B |
| Timers | | | | | |
| Pause (3 sec) R B G | Timer on (20 sec. to stop) G BK R G | Timer off G B BK R | Wins/Exits | | |
| | | | Win/Exit (Play Again) G B | Win/Exit (Game Over) G R | |
| Counters See reverse for definitions | | | | | |
| Enable X-ing Counter G R B G | Enable Turn Counter R B G B | Enable Path Color Counter R G B R | Enable Point Counter R B R G | Point +1 R B G | Point -1 G B R |

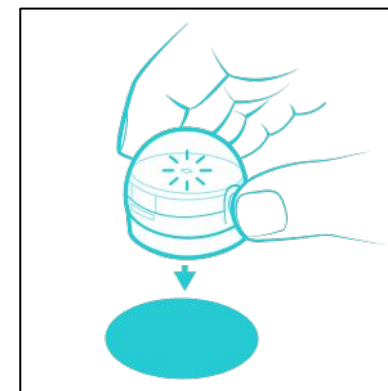

<https://ozobot.com/create/color-codes>

<https://ozobot.com/support/calibration>